

OEM4S 4.5 digit LCD digital voltmeter

features

- 4.5 Digit 12.2mm character height LCD
- Dual Range 200mV and 2V sensitivity
- Automatic zeroing and polarity indication
- Low battery indication
- 13 selectable annunciators
- Easy to use decimal point selection
- Display Hold as standard

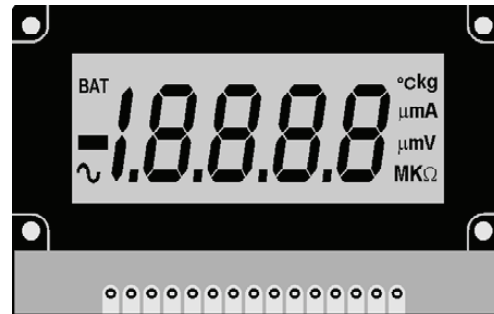

DESCRIPTION

The OEM4S is a neat "flat pack" voltmeter module that can either be sub-panel mounted or used with the optional MB11S fixing bezel. For greater accuracy, this 4.5 digit display gives increased resolution with the last digit counting in increments of 10µV. The module is set up for 9 volt operation but can be adjusted for 5V use. Low battery annunciator and display hold functions are provided as standard.

DIMENSIONS

mm

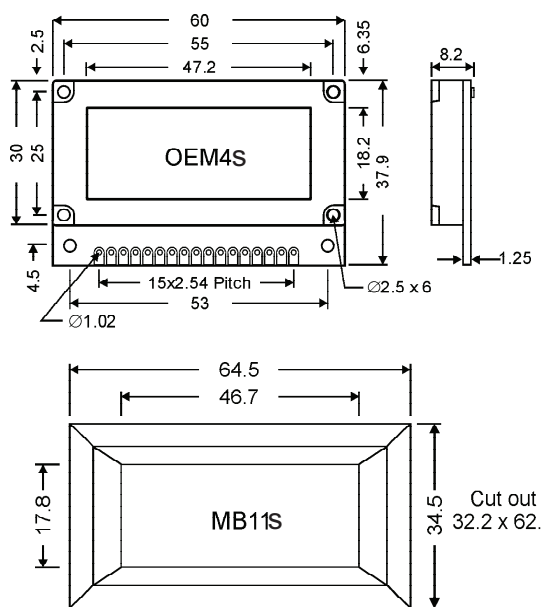

OPERATING SPECIFICATION

Operating temperature	0 to 50°C
Storage temperature	-10 to 60°C
Operating relative humidity	80%

ORDERING INFORMATION

OEM4S	4.5 digit, 200mV LCD Voltmeter
MB11S	Optional mounting bezel

ELECTRICAL CHARACTERISTICS $T_A = 25^\circ\text{C}$

CHARACTERISTIC	CONDITION	MIN	TYP	MAX	UNITS
Supply voltage (VDD)	9 volts	6	9	12	Volts
	5 volts	4.2	5	6	Volts
Supply Current (IDD)	9 Volts		800	1,300	µA
	5 Volts		2		mA
Full scale				199.99	mV
Input impedance		100			MΩ
Ref voltage ROH	9 Volts		100		mV
Overload voltage				20	Volts
Zero I/P Reading			0	±2	Count
Accuracy at FSD	9 volts		±5	±8	Counts
	5 volts		±5	±10	Counts
Resolution			10		µV
CMRR			110		dB
Temp Coefficient			100	150	ppm/°C
Low Battery Ind.	9 Volts only	6.3	7.2	7.7	V

PIN FUNCTIONS

PIN	DESCRIPTION
VDD	Positive supply terminal
VSS	Negative supply terminal
INHI	Positive input terminal
INLO	Negative input terminal
RFH	Reference input high terminal
RFL	Reference input low terminal
ROH	Reference output high terminal
ROL	Reference output low terminal
HOLD	Connect to VDD for display hold
COM	Analogue common
Range	Connect to VDD to change maximum input range from 200mV to 2V
DP1, DP2, DP3, DP4	Decimal point select. The required decimal point will energize when connected to VDD.
BAT, °C, µA, mA, µmV, M, K, Ω, HOLD	Annunciators. See user instructions.

Revision 1 22/11/05

Anders Electronics plc (Anders) does not warrant the accuracy or completeness of the information contained herein, the supply of products by Anders is subject to its standard terms and conditions of sale. Prior to concluding any agreement with Anders the customer should satisfy itself of the accuracy and completeness of the information contained herein and should notify to Anders any intended use of the product.

www.anders.co.uk | info@anders.co.uk

USER INSTRUCTIONS

The OEM4S is designed for 9/5V supply. Incorrect supply polarity will destroy the module immediately. It is ready for general use when connected as in figure 1, for 9V supply. For 5V supply, the module must be calibrated before use as follows. Connect as in figure 2, apply 100mV to the inputs, from a calibrated source and adjust VR1 until the display reads 10000.

The standard input range is 0-200mV. Over-range is indicated by blanking the three least significant digits and displaying a "1" in the most significant digit.

For 9V operation it is recommended to power from a 9V battery. The inputs are intended to float with respect to the supply but if they do not float they must be no closer than 1.5V from either VDD or VSS (VDD-1.5V and VSS+1.5V). See the circuits for non-floating inputs below. The low BAT voltage operates at around 7.2V

CONNECTION DIAGRAM

BASIC CONFIGURATION

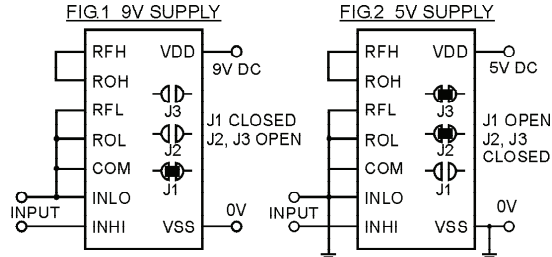

All annunciators are connected to a backplane for suppression purposes. To light up, cut the fine track between the required annunciator and the BP track and then link with solder the annunciator to the rectangular drive pad next to it.

For 5V operation, INLO must always be connected COM. For non floating inputs it should also be connected to VSS (as fig. 2).

DC VOLTAGE MEASUREMENT

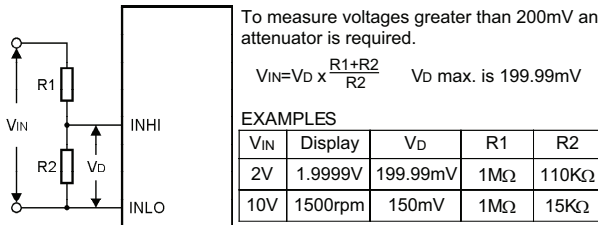

The input impedance becomes R1+R2. Choose accurate stable resistors. Typically, R1=1MΩ. 9MΩ is a practical upper limit.

MULTI-RANGE DC VOLTAGE MEASUREMENT

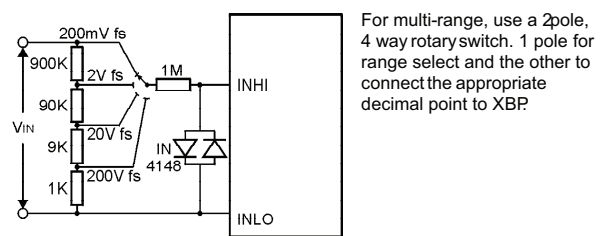

DC CURRENT MEASUREMENT

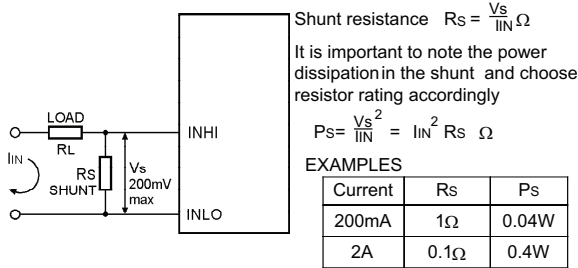

MULTI-RANGE DC CURRENT MEASUREMENT

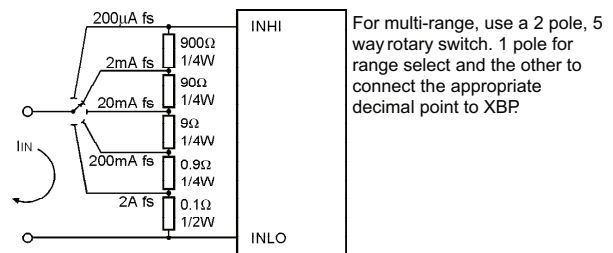

DC VOLTAGE OFFSET

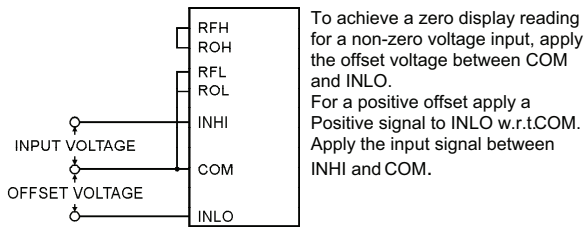

DC VOLTAGE RATIO MEASUREMENT

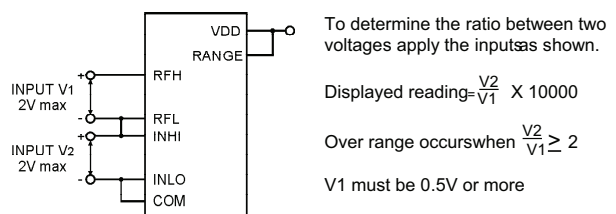

NON FLOATING INPUTS (a)

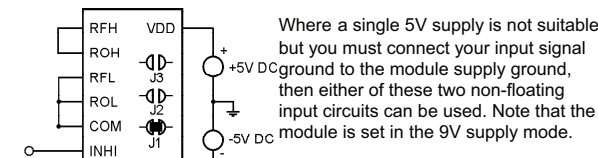

NON FLOATING INPUTS (b)

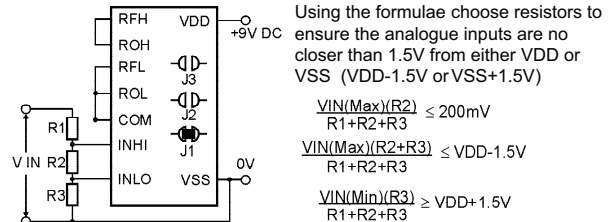

anders electronics plc Bayham Place, London NW1 OEU UK
Tel: +44 (0)20 7380 8167 Fax: +44 (0)20 7874 1908 <http://www.anders.co.uk>

Anders Electronics plc (Anders) does not warrant the accuracy or completeness of the information contained herein, the supply of products by Anders is subject to its standard terms and conditions of sale. Prior to concluding any agreement with Anders the customer should satisfy itself of the accuracy and completeness of the information contained herein and should notify to Anders any intended use of the product.

www.anders.co.uk | info@anders.co.uk

