

OEM035C 3.5 digit LCD 4-20mA Current Loop Module

features

- Powered by 4-20mA input signal
- 12.7mm digit height
- Adjustable offset and span
- Selectable decimal point
- Screw terminal block for easy connection
- Panel mounted with optional mounting bezel

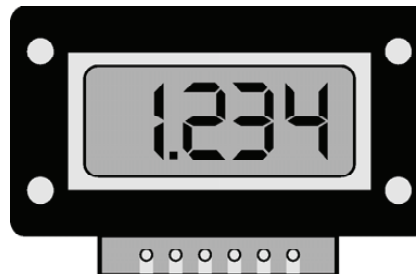

DESCRIPTION

The OEM035C is a complete digital current loop meter module for displaying engineering units from a 4-20mA transmitter. The meter is powered from the transmitter so no external power source is required.

The transmitter loop is terminated by a low impedance and a zener diode holding the signal at 2.5V. this voltage powers the circuitry.

ELECTRICAL CHARACTERISTICS $T_A=25^{\circ}\text{C}$

CHARACTERISTIC	MIN	TYP	MAX	UNIT
Accuracy		0.1±1		% ± digit
Sampling Rate		2.5		reading/sec
Voltage Drop	2.5		3.0	Volts
Zero offset at 4mA	-350		350	counts
Scale span at 20mA	200		1999	counts
Temperature coefficient		100		PPM/°C

DIMENSIONS

mm

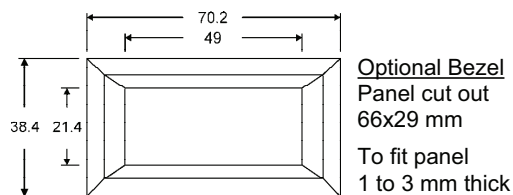
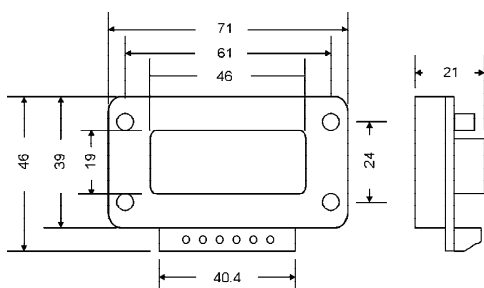

Installation diagram

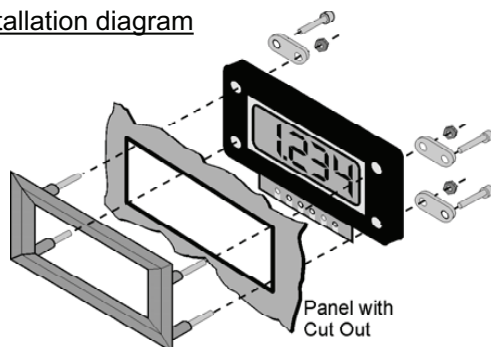

OPERATING SPECIFICATION

Operating temperature	0 to 50°C
Storage temperature	-10 to 80°C
Relative humidity	Below 80%

PIN FUNCTIONS

PIN	SYMBOL	DESCRIPTION
1	I+	Positive current loop input
2	I-	Negative current loop input
3	DP3	Decimal point select. On when connected to DP.com Off when left floating
4	DP2	
5	DP1	
6	DP.com	

CALIBRATION PROCEDURE

Example:

You have 4-20mA K type thermo-transmitter.
Temperature range -150 to 1200°C. (total span 1350°C)

1. Input 4mA and adjust VR2 (offset) to give zero reading.
2. Input 20mA and adjust VR1(span) to give 1350 reading.
3. Input 4mA and adjust VR2 (offset) to give -150 reading.
4. Input 20mA and adjust VR1(span) to give 1200 reading.
5. Repeat steps 3 and 4 for higher accuracy.

ORDERING INFORMATION

OEM035C	3.5 Digit 4-20mA Current Loop Module
MB501	Optional Black ABS Mounting Bezel

anders electronics plc Bayham Place, London NW1 OEU UK

Revision- 3 09/01/06

Tel:+44(0)20 7380 8167 Fax:+44(0)20 7874 1908 <http://www.anders.co.uk>